

## Specification-Free Match

Model	Indoor		AUMD-H12/NDR3HM2B	AUMD-H18/NDR3HM2B	AUMD-H24/NDR3HM2B
Capacity	Cooling	Btu/h	12000(4600-15000)	18000(5200-19100)	24000(7400-28000)
		KW	3.52(1.35-4.40)	5.28(1.53-5.60)	7.03(2.16-8.20)
	Heating	Btu/h	13000 (4200-18100)	19100(4800-21200)	27000(6800-31700)
		KW	3.81(1.24-5.30)	5.60(1.40-6.20)	7.91(1.98-9.30)
Electric Data	Rated Cooling Power Input	kW	220~240,50,1	220~240,50,1	220~240,50,1
	Rated Heating Power Input	kW	60	90	150
	Heating Power Input	W	60	90	150
Air Volume	Air Volume	CFM	423/352/294	530/441/370	824/700/576
		m3/h	720/600/500	900/750/630	1400/1190/980
	Sound Pressure Noise Level	dB(A)	36/34/32	41/37/34	42/39/36
	Sound Power Noise Level	dB(A)	49	56	55
	ESP	Pa	25(0~80)	25(0~80)	25(0~80)
Dimension	Net Dim (W*D*H)	mm	700x700x245	700x700x245	1000x700x245
	Packing Dim(W*D*H)	mm	930x830x300	930x830x300	1230x830x300
Weight	Net	kg	21	22	29.5
	Gross	kg	25	26.5	35.5
Refrigerant Type			R32	R32	R32
Pipe Dia	Liquid Side	mm(inch)	6.35(1/4)	6.35(1/4)	9.52(3/8)
	Gas Side	mm(inch)	12.7(1/2)	12.7(1/2)	15.88(5/8)
	Drainage	mm	R3/4in(DN25)	R3/4in(DN25)	R3/4in(DN20)
Loading Qty	20/40/40H	unit	61/137/159	61/137/159	42/89/99

## Dimension

AUMD-H12/NDR3HM2B AUMD-H18/NDR3HM2B

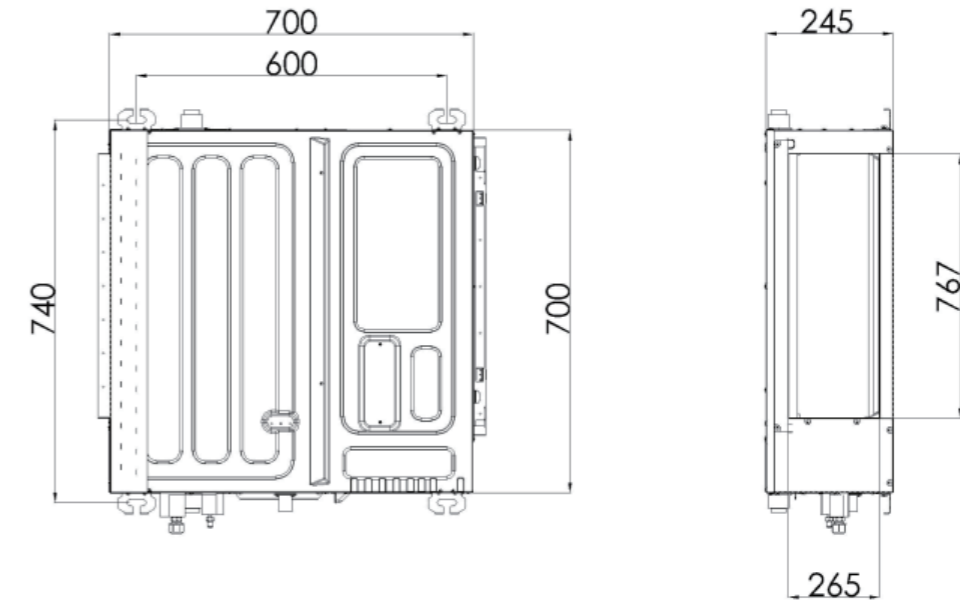

AUMD-H24/NDR3HM2B

