

RHR HEAT RECOVERY UNIT CATALOGUE



CE

 **Renair**

Inner air quality and energy efficiency are the new trends for offices , residences , houses and such places. Heat recovery units are perfect solution for these needs and they are highly demanded. Heat Recovery units are exhausting stall air while supplying fresh air. While changing the stall air with fresh air, it transfers the energy of the inner air to the fresh air through a heat exchanger without mixing the stall air with fresh air. So finally, the need for fresh air had been supplied and energy had been saved through the unit.

Main functions of the unit are:

- Exhausting stall air
- Supplying fresh air
- Filtering fresh air
- Recovering energy of the inner air by transferring their energy to supplied fresh air

Specifications

- Easy mounting of the unit thanks to alternative exits
- Easy maintenance to all components
- Optional usage with electrical heater or water coil
- High thermal efficiency
- Low noise level thanks to high efficient plug fans
- Flameproof type isolation
- G4 class filter
- 5 speed fans
- Smart automation of the unit with optional automation boards

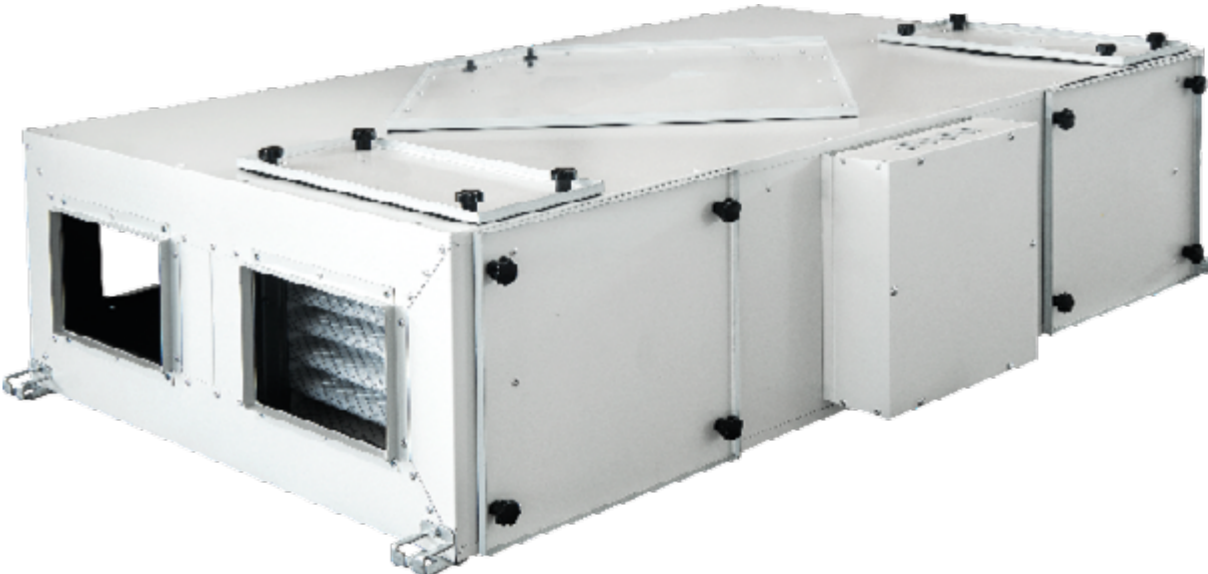

Easy Maintenance of the Components

- Heat recovery ventilators need periodical maintenance. All components of the unit are mounted on the rails letting them easily out for maintenance. The filters should be serviced after 1.200 working hours which automation reminds service time.

High Efficient Exchangers

- The exchangers having certified performances are being used in our heat recovery ventilators. They are high efficient, thanks to design and structure, which creates big amount of energy saving. This saving also decreases total heating and cooling needs of the area where they are planned to be used.

Plug Type Fans

- AC, Plug type fans are preferred because of their high efficiency and low noise levels.

Body of RHR and Inner Insulation

- RHR units body is 0,8mm RAL 7040 purpa coated sheet metal for outer surface and 0,8mm galvanised sheet metal for the inner parts. The inner surface of the body of the unit is covered with an insulation material which is flame retardant and has thickness of 10 mm. Thanks to special insulation material, unit has a perfect sound and thermal insulation.



Technical Specifications

		RHR								
		800	1000	1500	2000	2500	3000	4000	5000	6000
Electrical Connections		1~230 V 50 Hz								
Air Flow [1]	m³/h	800	1000	1500	1900	2400	2970	3830	4700	5200
Sound Level [2]	dB (A)	44	45	46	48	49	50	52	53	59
Electrical Requirements										
Fan/motor Power [3]	W	204	310	420	1030	1030	750	940	1360	1900
Maximum Current	(A)	0,9	1,4	1,9	4,5	4,5	3,5	4,7	6	6

¹ Airflow data when the ESP is 0 Pa.
² Sound levels are measured at 250Hz and at 1,5m distance.
³ Power consumption

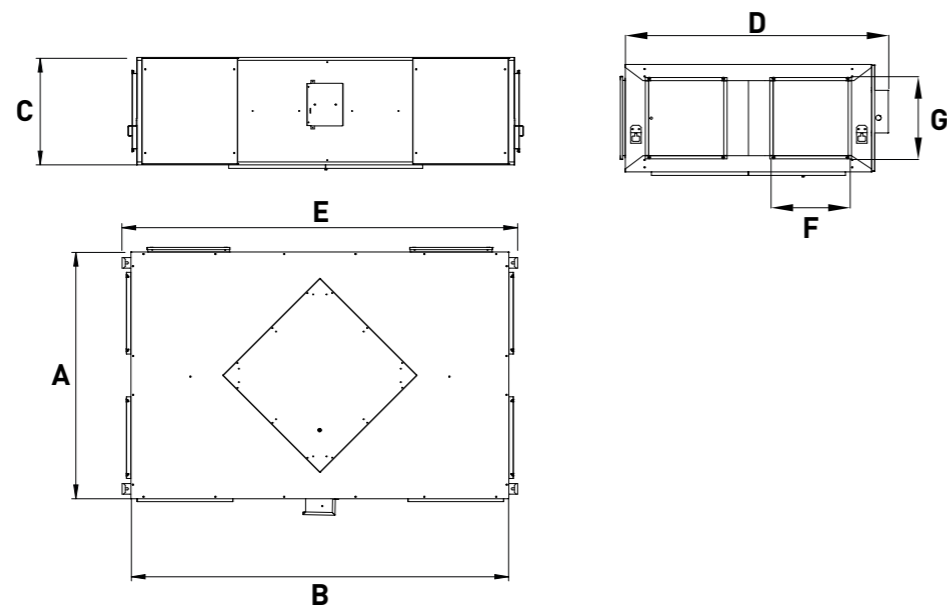

		Dimensions (mm)							Weight (kg)
MODEL	A	B	C	D	E	F	G		
800	660	1230	355	795	1312	200	200	51	
1000	660	1230	355	795	1312	200	200	52	
1500	910	1430	360	1045	1510	170	270	72	
2000	910	1430	430	1045	1510	250	300	84	
2500	1170	1790	425	1300	1870	300	300	103	
3000	1170	1790	515	1300	1870	370	370	116	
4000	1170	1890	515	1300	1970	370	370	125	
5000	1380	1990	645	1455	2070	432	432	186	
6000	1380	1990	645	1455	2070	432	432	199	

Performance Datas

► RHR 800 / Air Flow Performance

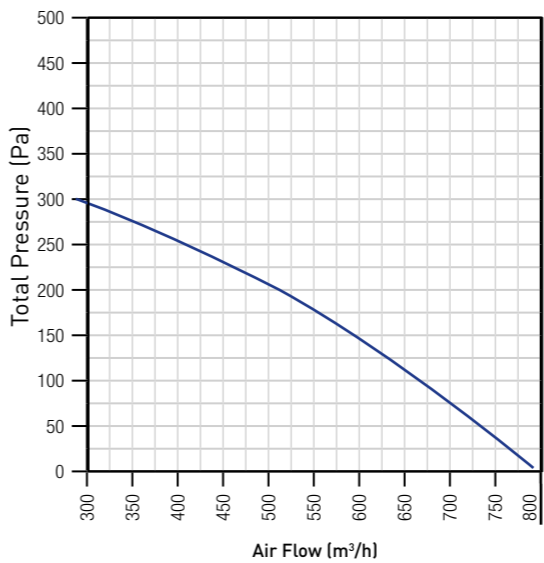

Model	RHR 800	
Power Supply	220 - 240 V / Single Phase / 50 Hz	
Max. Power Consumption	W	204
Air Flow	m³/h	800
External St. Pressure	Pa	0
SFP Results	kW/(m³/s)	0,898
Temp. Exc. Efficiency	%	53
Sound	dB	44

$$\text{Temperature Efficiency; } \eta_T = \frac{T_2 - T_1}{T_3 - T_1} \times 100 \%$$

Outdoor Air; -3°C, 75% RH

Return Air; 22°C, 50% RH

Sound Power Level is measured 1.5 m away from the unit at 250 HZ.

► RHR 1000 / Air Flow Performance

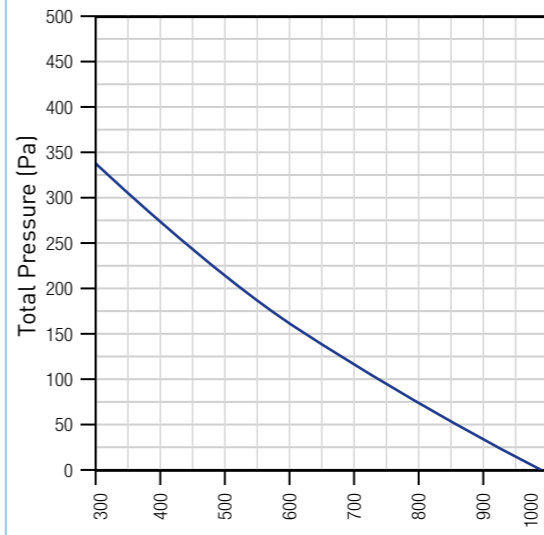

Model	RHR 1000	
Power Supply	220 - 240 V / Single Phase / 50 Hz	
Max. Power Consumption	W	310
Air Flow	m³/h	1000
External St. Pressure	Pa	0
SFP Results	kW/(m³/s)	0,975
Temp. Exc. Efficiency	%	51
Sound	dB	45

$$\text{Temperature Efficiency; } \eta_T = \frac{T_2 - T_1}{T_3 - T_1} \times 100 \%$$

Outdoor Air; -3°C, 75% RH

Return Air; 22°C, 50% RH

Sound Power Level is measured 1.5 m away from the unit at 250 HZ.

Performance Datas

► RHR 1500 / Air Flow Performance

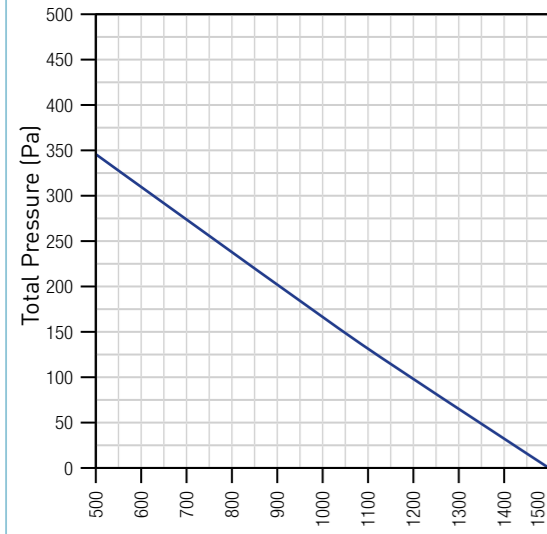

Model	RHR 1500	
Power Supply	220 - 240 V / Single Phase / 50 Hz	
Max. Power Consumption	W	420
Air Flow	m³/h	1500
External St. Pressure	Pa	0
SFP Results	kW/(m³/s)	1,217
Temp. Exc. Efficiency	%	50
Sound	dB	46

$$\text{Temperature Efficiency; } \eta_T = \frac{T_2 - T_1}{T_3 - T_1} \times 100 \%$$

Outdoor Air; -3°C, 75% RH

Return Air; 22°C, 50% RH

Sound Power Level is measured 1.5 m away from the unit at 250 HZ.

Performance Datas

► RHR 2500 / Air Flow Performance

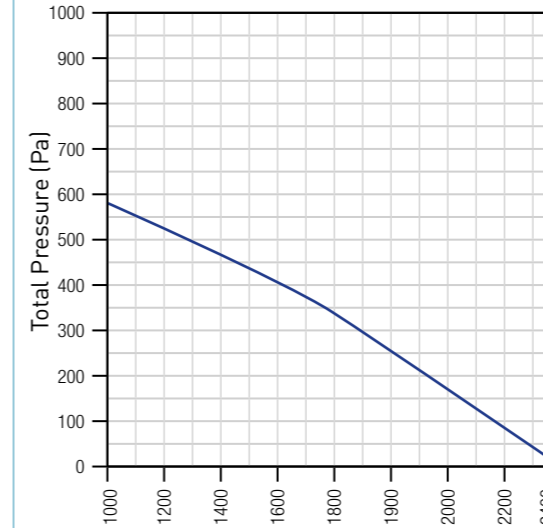

Model	RHR 2500	
Power Supply	220 - 240 V / Single Phase / 50 Hz	
Max. Power Consumption	W	1030
Air Flow	m³/h	2400
External St. Pressure	Pa	0
SFP Results	kW/(m³/s)	1,158
Temp. Exc. Efficiency	%	50
Sound	dB	59

$$\text{Temperature Efficiency; } \eta_T = \frac{T_2 - T_1}{T_3 - T_1} \times 100 \%$$

Outdoor Air; -3°C, 75% RH

Return Air; 22°C, 50% RH

Sound Power Level is measured 1.5 m away from the unit at 250 HZ.

► RHR 2000 / Air Flow Performance

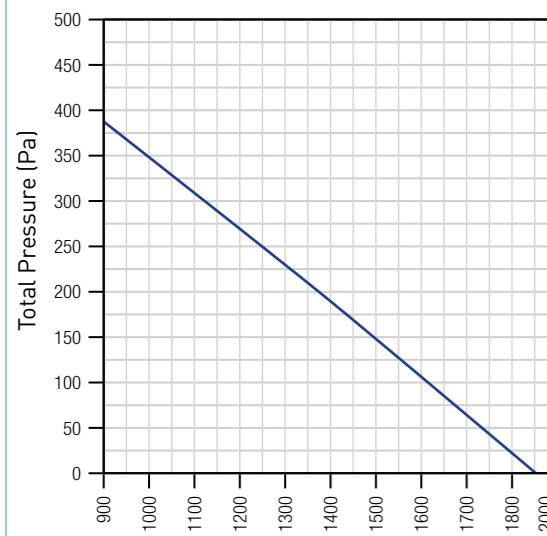

Model	RHR 2000	
Power Supply	220 - 240 V / Single Phase / 50 Hz	
Max. Power Consumption	W	1030
Air Flow	m³/h	1900
External St. Pressure	Pa	0
SFP Results	kW/(m³/s)	1,121
Temp. Exc. Efficiency	%	52
Sound	dB	48

$$\text{Temperature Efficiency; } \eta_T = \frac{T_2 - T_1}{T_3 - T_1} \times 100 \%$$

Outdoor Air; -3°C, 75% RH

Return Air; 22°C, 50% RH

Sound Power Level is measured 1.5 m away from the unit at 250 HZ.

► RHR 3000 / Air Flow Performance

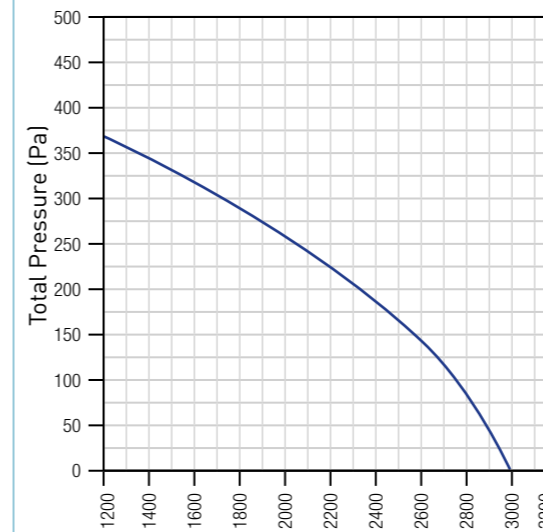

Model	RHR 3000	
Power Supply	220 - 240 V / Single Phase / 50 Hz	
Max. Power Consumption	W	750
Air Flow	m³/h	2970
External St. Pressure	Pa	0
SFP Results	kW/(m³/s)	1,118
Temp. Exc. Efficiency	%	51
Sound	dB	50

$$\text{Temperature Efficiency; } \eta_T = \frac{T_2 - T_1}{T_3 - T_1} \times 100 \%$$

Outdoor Air; -3°C, 75% RH

Return Air; 22°C, 50% RH

Sound Power Level is measured 1.5 m away from the unit at 250 HZ.

Performance Datas

► RHR 4000 / Air Flow Performance

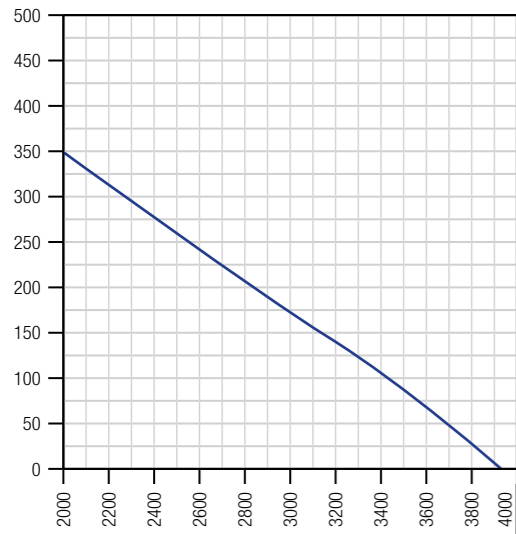

Model	RHR 4000	
Power Supply	220 - 240 V / Single Phase / 50 Hz	
Max. Power Consumption	W	940
Air Flow	m³/h	3830
External St. Pressure	Pa	0
SFP Results	kW/(m³/s)	1,268
Temp. Exc. Efficiency	%	50
Sound	dB	52

$$\text{Temperature Efficiency; } \eta_T = \frac{T_2 - T_1}{T_3 - T_1} \times 100 \%$$

Outdoor Air; -3°C, 75% RH

Return Air; 22°C, 50% RH

Sound Power Level is measured 1.5 m away from the unit at 250 HZ.

► RHR 5000 / Air Flow Performance

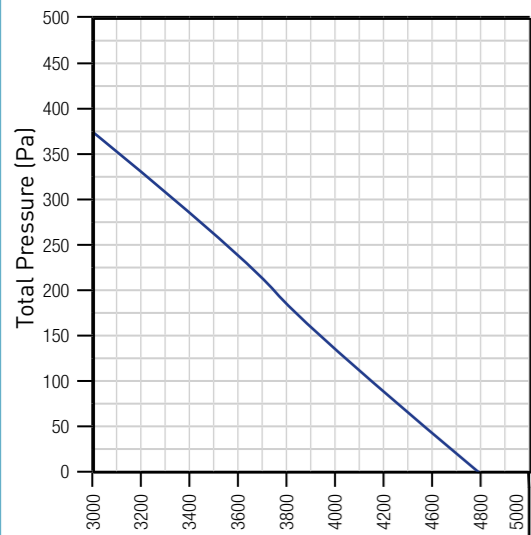

Model	RHR 5000	
Power Supply	220 - 240 V / Single Phase / 50 Hz	
Max. Power Consumption	W	1360
Air Flow	m³/h	4700
External St. Pressure	Pa	0
SFP Results	kW/(m³/s)	1,374
Temp. Exc. Efficiency	%	50
Sound	dB	53

$$\text{Temperature Efficiency; } \eta_T = \frac{T_2 - T_1}{T_3 - T_1} \times 100 \%$$

Outdoor Air; -3°C, 75% RH

Return Air; 22°C, 50% RH

Sound Power Level is measured 1.5 m away from the unit at 250 HZ.

Performance Datas

► RHR 6000 / Air Flow Performance

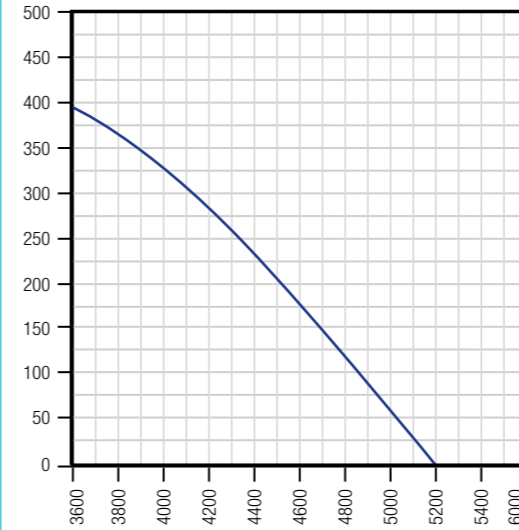

Model	RHR 6000	
Power Supply	220 - 240 V / Single Phase / 50 Hz	
Max. Power Consumption	W	1900
Air Flow	m³/h	5200
External St. Pressure	Pa	0
SFP Results	kW/(m³/s)	1,452
Temp. Exc. Efficiency	%	50
Sound	dB	52

$$\text{Temperature Efficiency; } \eta_T = \frac{T_2 - T_1}{T_3 - T_1} \times 100 \%$$

Outdoor Air; -3°C, 75% RH

Return Air; 22°C, 50% RH

Sound Power Level is measured 1.5 m away from the unit at 250 HZ.

Duct Connection Configuration

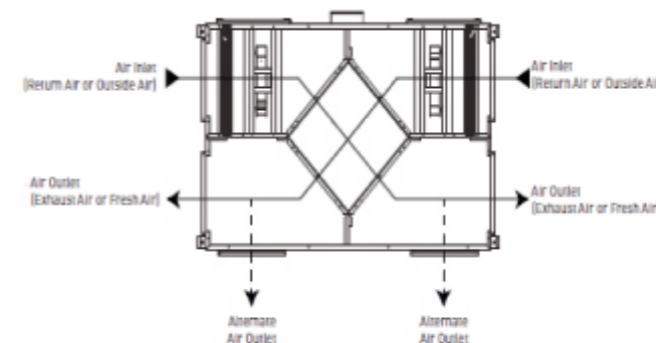
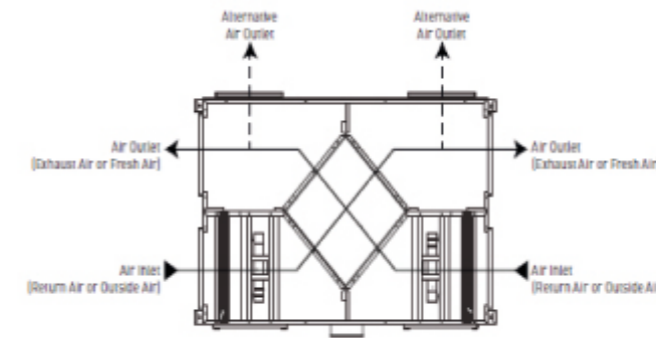

Accessories

► Digital Controller



► Standard Panel Specifications

- 1 Manages exhaust and fresh air fan volumes individually in 5 steps.
- 2 Filter service alarm after 1200 hours of performance.
- 3 Thermal protection for motors.

► Pro Panel Specifications

- 1 Manages exhaust and fresh air fan volumes individually in 5 steps
- 2 Filter service alarm after 1200 hours of performance
- 3 Thermal protection for motors
- 4 Electrical heater connection
- 5 Water Coil connection
- 6 Protection of heaters for over-heating
- 7 Boost Function
- 8 Carbondioxide sensor connection
- 9 On/Off and proportional control of the water coil.
- 10 Control of damper motor
- 11 BMS control
- 12 Control of heating and cooling coil valves
- 13 Fire alarm
- 14 Weekly programming
- 15 Thermal check with a sensor located on duck

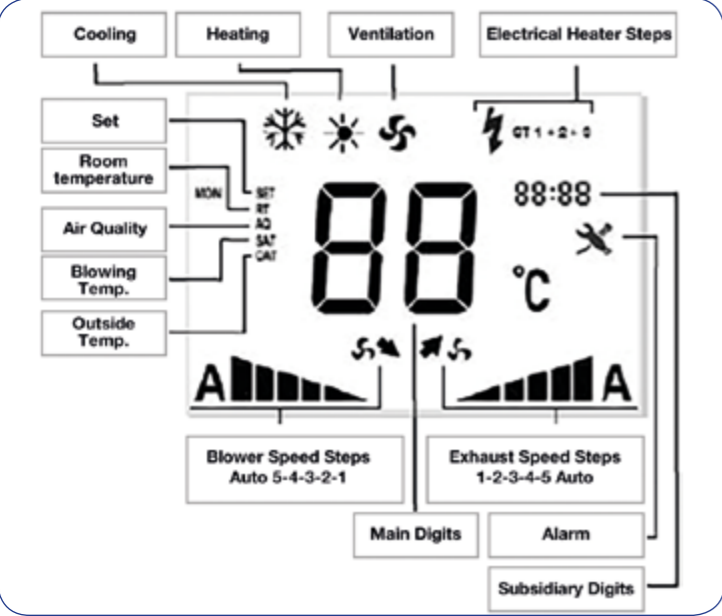

► Advanced Panel Specifications

- 1 Manages exhaust and fresh air fan volumes individually in 5 steps
- 2 Filter service alarm after 1200 hours of performance
- 3 Thermal protection for motors
- 4 Electrical heater connection
- 5 Water Coil connection
- 6 Protection of heaters for over-heating
- 7 Boost Function

Accessories



► Digital Room Controller

RHR units are supplied with a digital room control panel. It can control air flow while changing the exhaust and fresh air flows individually(L/M/H).All the changes could be followed on LCD screen.The mode of the unit can be adjusted to winter or summer.In summer mode only the unit works. In winter mode, Unit and electrical heater works. According to the temperature adjusted on the control panel, electrical heater start up automatically. The "off " button on the control panel stops both electrical heater and unit.

Electrical board comes with the unit, it adopts unit orders coming from room controller.Components like relay,contactor,capacitor and connector are located in electrical board. Required electrical power should be supplied to heater and also to unit

RHR Units can connect to Building Automation System via contactor or MODBUS(RS485).Thereby all the features of the unit can be controlled through a centralized system.

Fresh air and return air flows can be adjusted with automation panel.Thus,negative or positive pressure could be obtained.



Renair İklimlendirme Sistemleri
Sanayi ve Ticaret A.Ş.

+90 236 214 04 34 www.renair.com.tr

Muradiye Mah. 18 Sk.Sanatkarlar Koop. Sit.
Şevki Baydar Apt. No:8 Yunusemre / Manisa

RENAIR reserves the right to change the catalog information without prior notice, due to continuous product improvement process of RENAIR R&D department.