

# Technical Data Sheet

CODE 42346

## A-E 506 T

Compact plate axial fans



### Certifications



### TECHNICAL AND PERFORMANCE DATA

Absorbed Current max (A)	0.79	Voltage (V)	380-415
Absorbed Power max (W)	250	Weight (Kg)	15.0
Frequency (Hz)	50	Delivery max (l/s)	1400
Insulation Class	I°	Delivery max (m³/h)	5040
IP	54	Pressure max - max speed (mmH20)	9.8
Max ambient temperature for continuous operation (°C)	50	Pressure max (Pa)	96
Motor IP protection	54	RPM	1000
Nominal Diameter (mm)	500	Sound power level Lw [dB(A)]	73.2
Number of Phases (Ph)	3	Sound pressure level Lp in free field [dB(A)] 1 m	62.2
Number of Poles	6	Sound pressure level Lp in free field [dB(A)] 3 m	52.7

### DIMENSIONS

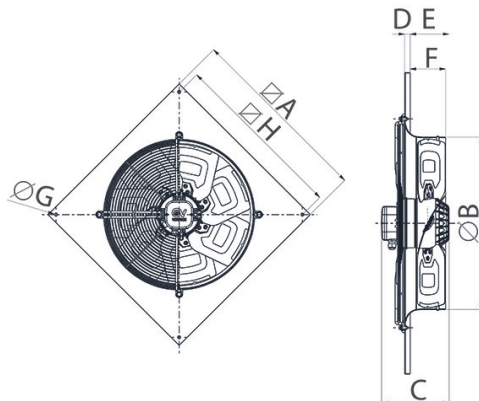

Size A (mm)	630
Size B (mm)	508
Size C (mm)	198
Size D (mm)	16
Size E (mm)	114
Size F (mm)	105
Size G (mm)	11
Size H (mm)	530

#### PER INFORMAZIONI:

Servizio al Cliente: tel +39 02 90699395 premendo 1 dopo messaggio registrato (consulenza su prodotti e impianti)

Pre & Post Vendita: fax +39 02 90699302

Email prevendita: [prevendita@vortice-italy.com](mailto:prevendita@vortice-italy.com)

# Technical Data Sheet

CODE 42346

A-E 506 T

Compact plate axial fans



## DESCRIPTION

- Nominal diameter 500 mm
- Panels made of pressed steel, phosphated and epoxy powder coated with hammered effect finish, guaranteeing long-term resistance to atmospheric agents.
- Ventilation port fashioned in one piece with the panel, gauged to optimize air flow, aerodynamically contoured and elongated to optimize performance and facilitate connection to the relative duct.
- Protective grille (in accordance with UNI ISO 13857 standard) combining the function of motor bracket, made of electrically welded steel with epoxy paint finish, colour black. Easy removal simplifies maintenance and cleaning of the fan.
- 1 speed three-phase AC motor of external rotor type designed to minimize axial dimensions, with shaft turning in ball bearings, insulation class F, thermal overload protection.
- Maximum air flow 4844 m<sup>3</sup>/h
- Dynamically balanced impeller (UNI ISO 1940, Point 1 – Class 6.3); 4 pressed steel blades, electrolytically galvanized and polyester powder-coated, colour black.
- Vortice speed controller.

## CURVES

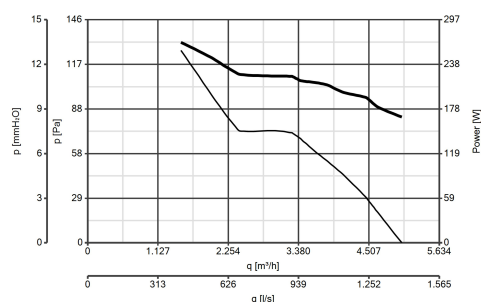

## ACCESSORIES



IRT 15  
Code 12923



IRT 35  
Code 12924



PGR 450/500  
(PERSIANA  
GRAVITA')  
Code 50550

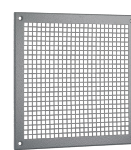

TRA 450/500  
(TELAIO CON  
RETE ANTINF.)  
Code 51550

### PER INFORMAZIONI:

Servizio al Cliente: tel +39 02 90699395 premendo 1 dopo messaggio registrato (consulenza su prodotti e impianti)

Pre & Post Vendita: fax +39 02 90699302

Email prevendita: [prevendita@vortice-italy.com](mailto:prevendita@vortice-italy.com)