



Aroma

# Aroma



## Control from Nethome PLUS application

This application allows you to control the air-conditioner from any place on earth.

## Aromatic filter

The air-conditioner is optionally equipped with an aromatic filter, which ensures feeling of jasmine freshness for several weeks.

## Functions

### STANDARD

(available with wireless remote controller R657A7(B)/BGEF)



WiFi control



Wireless remote controller (R657A7(B)/BGEF)



TURBO function



Emergency operation mode



Sleep mode



Timer



Restoring the louver settings



5 steps of fan speed regulation



Intelligent modulation of the fan rotational speed



1W in standby mode



Hot start



Auto restart



"Follow me" function



Operation in low ambient temperatures



Split and multi compatible



ECO



Self-cleaning



High density filter



Catalyst filter



Horizontal louver control



Refrigerant leakage detection



Manual switch



LED on/off

### OPTIONAL



bioHEPA filter



Aromatic filter



8°C heating with R657A6(B)/BGEF



Drain pump

## Technical specifications

Set				ZAF-09N8-B1-W	ZAF-12N8-B1-W	ZAF-18N8-B1-W	ZAF-24N8-B1-W	
Indoor unit				MSAFBU-09HRDN8-QRD-0GWX-W	MSAFBU-12HRDNX-QR-0DFGWX-W	MSAFBU-18HRFN8-QRD-0GW-W	MSAFBU-24HRFN8-QRD-0GW-W	
Outdoor unit				MOX133-09HFN8-QRD0GW	MOX133-12HFN8-QRD0GW	MOX330-18HFN8-QRD0GW	MOX431-24HFN8-QRD0GW	
Power supply (V/phase/Hz)				220-240/1/50				
Version				Reversible heat pump				
Cooling	Capacity	Rated	kW	2.6	3.5	5.3	7.0	
		Min-Max	kW	0.9-3.4	1.1-4.2	0.34-5.83	2.1-7.9	
	Rated input power		kW	0.73	1.21	1.55	2.60	
	EER		kW/kW	3.60	2.89	3.42	2.69	
	SEER			6.3	6.1	7.4	6.1	
Energy efficiency class				A++	A++	A++	A++	
Heating	Capacity	Rated	kW	2.9	3.8	5.6	7.3	
		Min-Max	kW	0.8-3.4	1.1-4.2	3.1-5.85	1.6-7.9	
	Rated input power		kW	0.73	1.10	1.57	2.40	
	COP		kW/kW	3.97	3.45	3.57	3.04	
	SCOP			4.0	4.0	4.0	4.0	
Energy efficiency class				A+	A+	A+	A+	
Maximum input current			A	10.0	10.0	10.0	16.0	
Indoor unit	Dimensions (width x depth x height)		mm	805×194×285	805×194×285	957×213×302	1040×220×327	
	Transport dimensions (width x depth x height)		mm	870×285×360	870×285×360	1035×305×380	1120×315×407	
	Weight (net/gross)		kg	7.6/9.8	7.6/9.8	10.0/13.0	12.3/15.8	
	Airflow (low/medium/high)		m <sup>3</sup> /min	5.4/6.0/7.7	5.1/7.1/9.0	9.0/11.3/14.0	11.0/13.6/16.3	
	Sound pressure level (low/medium/high)		dB(A)	25/32/38.5	25/34.5/40.5	26/36/42.5	36/40.5/45	
	Sound power level		dB(A)	54	55	56	59	
Outdoor unit	Dimensions (width x depth x height)		mm	720×270×495	720×270×495	805×330×554	890×324×673	
	Transport dimensions (width x depth x height)		mm	828×298×540	828×298×540	915×370×615	995×398×740	
	Weight (net/gross)		kg	23.2/25.0	23.2/25.0	32.7/35.4	42.9/45.9	
	Airflow		m <sup>3</sup> /min	29.2	30.0	35.0	58.3	
	Sound pressure level		dB(A)	55.5	56	55	59	
	Sound power level		dB(A)	62.0	63	63	67	
Refrigerant	Type			R32	R32	R32	R32	
	Charged amount		kg	0.55	0.55	1.08	1.42	
Refrigerant installation	Liquid/gas		mm	Ø6.35 / Ø9.52	Ø6.35 / Ø9.52	Ø6.35 / Ø12.7	Ø9.52 / Ø15.9	
	Maximum length		m	25	25	30	50	
	Maximum height difference		m	10	10	20	25	
Recommended electrical wiring and protections	Power supplied unit/cross-section		mm <sup>2</sup>	outdoor / 3×1.5	outdoor / 3×1.5	outdoor / 3×2.5	outdoor / 3×2.5	
	Transmission		mm <sup>2</sup>	5×1.5	5×1.5	5×1.5	5×1.5	
	Fuse		A	10	10	16	20	
Recommended operating temperature ranges (outdoor)			Cooling	°C				-15 - 50
			Heating	°C				-25 - 30

### Capacity is based on the following conditions:

Cooling: indoor temperature 27°C DB/19°C WB; outdoor temperature 35°C DB/24°C WB. Heating: indoor temperature 20°C DB/15°C WB; outdoor temperature 7°C DB/6°C WB. Installation length: length of connected pipes is 7.5 m, the height difference is 0. The unit contains fluorinated greenhouse gases (R32 GWP=675).

For the proper operation of outdoor units in the heat pump mode it is necessary to apply a drain pan heater or provide smooth condensate drain in another manner.

Choice of the appropriate solution is a matter for installer.

\* Function available with RG57A6(B)/BGEEF controller

## Accessories

Standard	
RG57A7(B)/BGEEF	Wireless remote controller
WIFI OSK-105	It allows to control from a Smartphone with NetHome Plus application.
Option	
KJR-29B	Individual wired remote controller with Follow Me function
RG57A6(B)BGEEF	Wireless remote controller with Frost Protect function

Detailed description of the controllers is available in the Control section.

## Indoor units

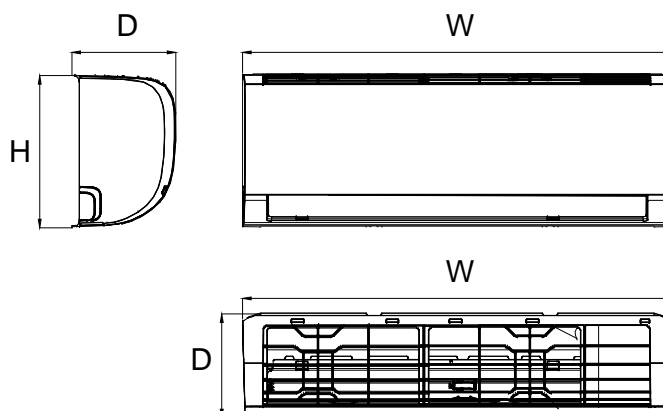

Model	Unit	W	D	H
MSAFBU-09HRDN8-QRDOGW X	mm	805	194	285
MSAFBU-12HRDNX-QRDOFGW X	mm	805	194	285
MSAFBU-18HRFN8-QRDOGW	mm	957	213	302
MSAFDU-24HRFN8-QRDOGW	mm	1040	220	310

## Outdoor units

MOX133-09HFN8-QRDOGW, MOX133-12HFN8-QRDOGW

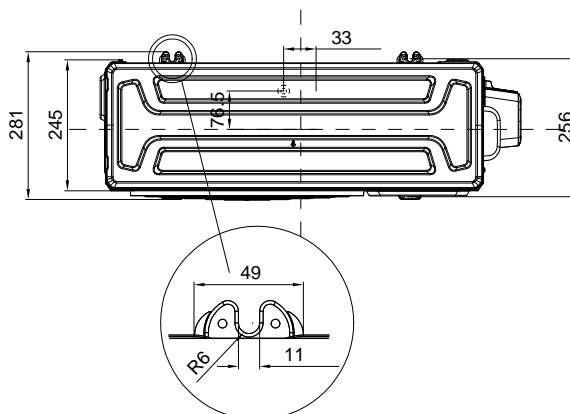
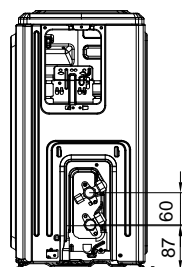
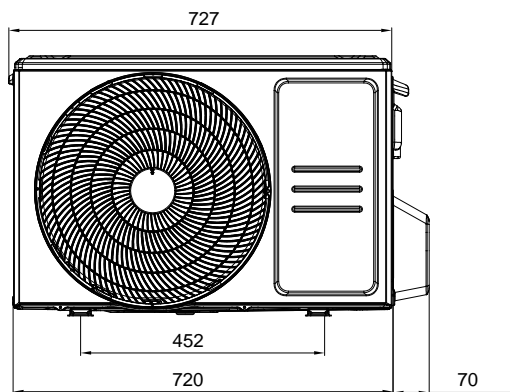
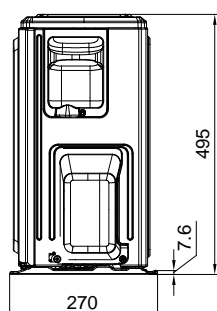

MOX330-18HFN8-QRDOGW

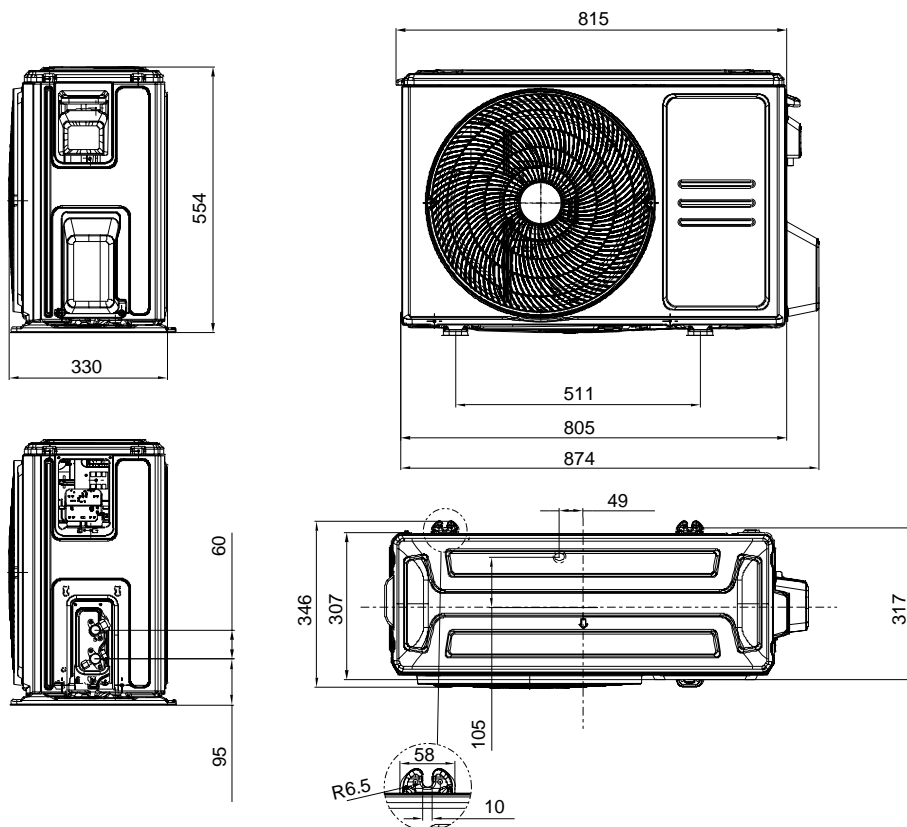

MOX431-24HFN8-QRDOGW

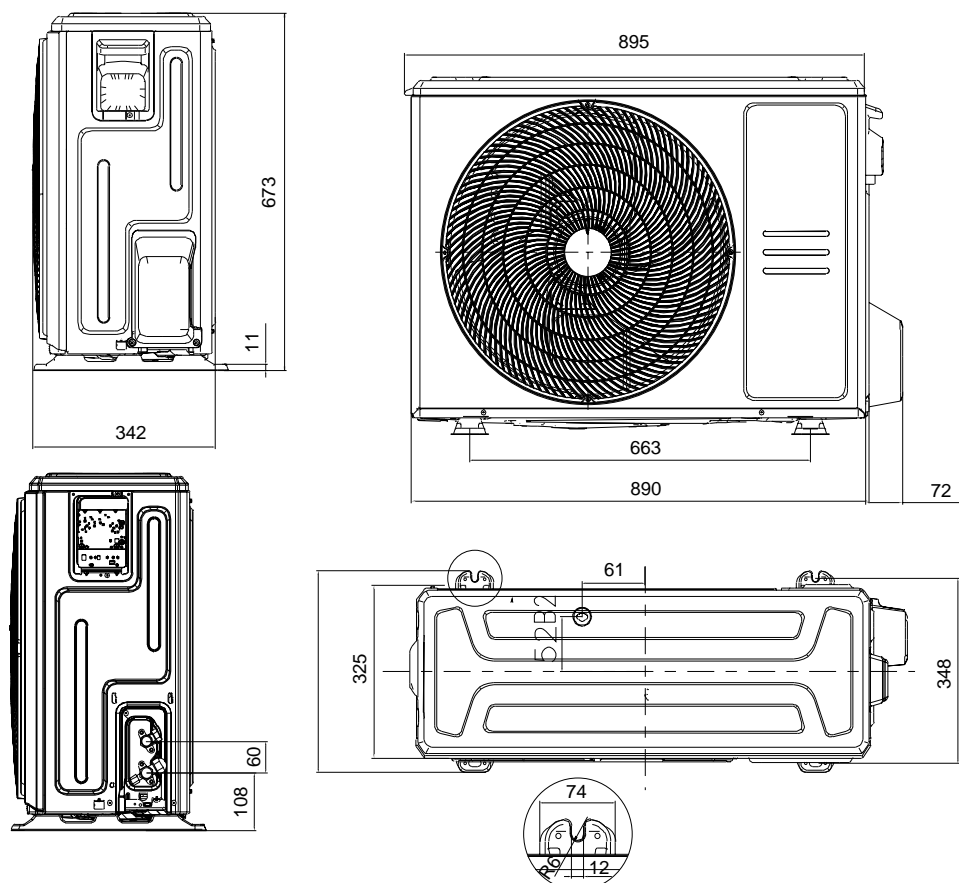

# Multi SERIES

